

VERSAsream VS-1208BT-S FASTstart Guide



What is included?

- (1) VS-1208BT-S w/ mounting bracket (for use with RMC-2 or RMC 12-2)
- (2) Power Supplies, Universal can be used worldwide
- (2) AC Power Cables (connector, in most cases, matches the country where the product is shipped)
- (1) DB-9 M-F Straight Through Serial Cable, 2m
- (1) Ethernet cable RJ45-RJ-45. 1m
- (1) CD with Flashutils software for upgrading firmware
- (1) Download Card (tells where to download more product information)

The VS-120 BT-S Network Packet Broker can be used in conjunction with network tools to provide enhanced security and visibility into the network. It can be utilized to widen the visibility of a single monitoring tool by aggregating links together, or when multiple tools are required, the VERSAsream can regenerate traffic to multiple tools.

Installation All 8 ports on the on the VS-1208BT-S are any-to-any ports. This means that any of the ports can be configured as input (network) or output (monitoring) ports on the fly through an easy to use command line interface (CLI) or Web-based management.

Connect TAPs, SPAN ports, and monitoring tools to the VERSAsream and set up port steering to aggregate or regenerate traffic from the input sources to the monitoring tools. See commands below for examples on steering traffic from port to port.

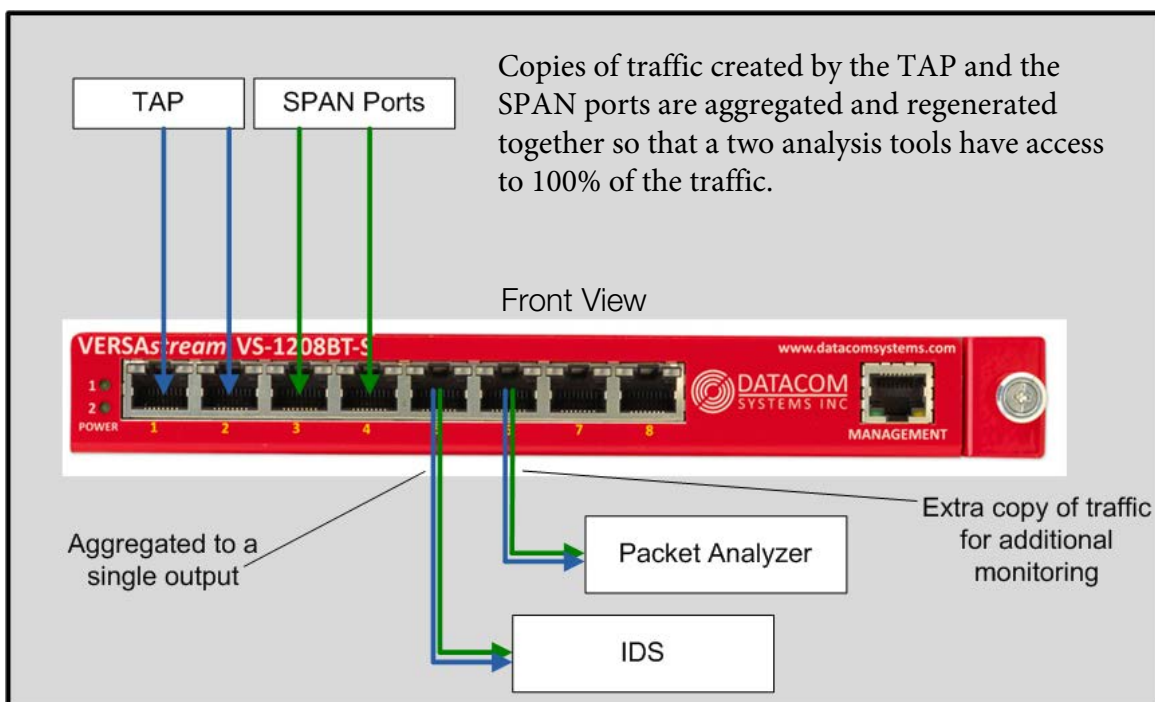

Aggregation

Give a single monitoring tool visibility to copies of traffic from multiple sources.



Regeneration

Make additional copies of traffic to share with multiple monitoring tools.

Setup

- Default login: Administrator
- Default password: admin
- Read/Write Login: su
- Read/Write password: password
- Serial port settings 8-N-1 No flowcontrol
- Default IP address: 192.168.1.1



Back View

Common Commands

- help (shows available commands)
- show (shows product firmware and mgt port settings)
- se po sp 5 AUTO (sets port 5 speed to AUTO, 1000FULL, 100FULL)
- se po mo 5 from 1,3 (steers traffic from ports 1 and 3 to port 5)
- se po mo 6 from 1,2,3,4 (steers traffic from ports 1, 2, 3, and 4 to port 6)
- se po mo 9 from 1 (steers traffic from port 1 to 9)
- se po mo 9 off (clears any traffic from going to port 9)
- exit (always use this when you leave your telnet/serial session, it automatically saves the configuration)

Find out more. Visit
www.datacomsystems.com

For More information

Customer Service is available from our website: www.datacomsystems.com or by calling +1 315 463 9541