

6 Connecting a T1/E1-PT to the the Network

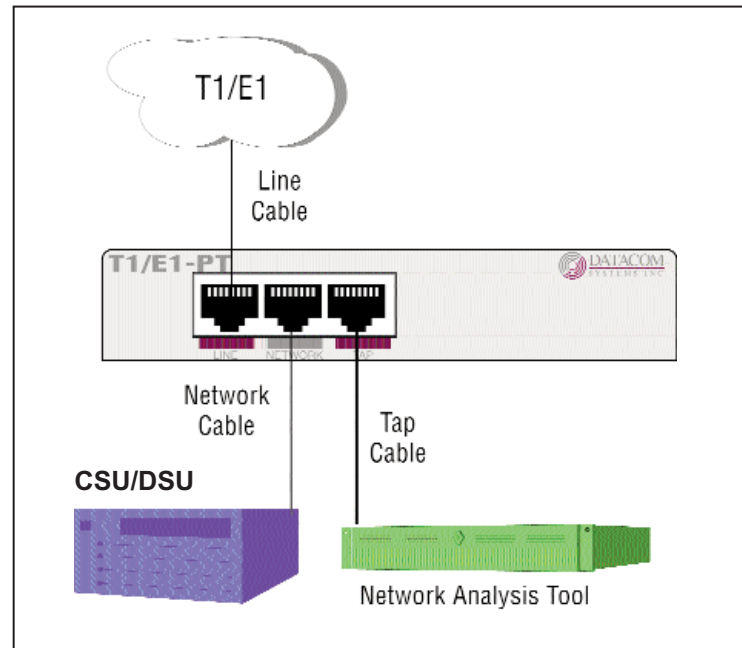

FIGURE 2 — T1/E1-PT Simple Connectivity Diagram

To connect the T1/E1-PT into the network, refer to **FIGURE 2** and follow these steps:

IMPORTANT: The maximum length of 90 meters must not be exceeded between end-points.

1. Connect one of the network device cables to the T1/E1-PT RJ45 port **LINE** connector.
2. Connect the other network device cable to the T1/E1-PT RJ45 port **NETWORK** connector.
3. Connect a tap cable from the T1/E1-PT RJ45 port **TAP** connector into the port of the Network Analysis Tool interface card.

Copyright

Copyright © 2004-2010 by Datacom Systems, Inc. All rights reserved. Printed in the United States of America. No part of this publication may be reproduced, stored in a retrieval system, or transmitted, in any form or by any means, electronic, mechanical, photocopying, recording, or otherwise, without the prior written permission of Datacom Systems, Inc. To obtain this permission, write to the attention of the Datacom Systems legal department at 9 Adler Drive, East Syracuse, New York 13057-1290, or call 315-463-9541.

Customer Service

This Quick Installation Guide was written to help you get to know your new DS3/E3-PT quickly and easily. We would welcome any comments or suggestions you may have regarding this Quick Installation Guide. Please send your remarks and recommendations via mail, telephone, facsimile, or Internet E-mail. via telephone, facsimile, and Internet E-mail. please leave a voice message and our Customer Service Staff will return your call as soon as possible.

Mail: Datacom Systems, Inc.
Customer Service
9 Adler Drive
East Syracuse, NY 13057-1290

Tel: (315) 463-9541

FAX: (315) 463-9557

E-mail: support@datacomsystems.com

World Wide Web

You can obtain additional information about Datacom Systems, Inc. and its products and services from the World Wide Web at <http://www.datacomsystems.com>.

DATACOMsystems®
T1/E1-PT Tap

Quick Installation Guide



May 2010

Part Number: 541-0077-A.02

Warranty

Datacom Systems, Inc. (DSI) warrants that the hardware which it supplies will be free from significant defects in materials and workmanship for a period of two years from the date of delivery (Warranty Period), under normal use and conditions. In the event of any such defect, you can return an item of defective hardware, freight prepaid, to DSI during the Warranty Period, and DSI will repair or replace the defective equipment and return it to you, freight prepaid. If DSI determines that the equipment is not defective, it will return it to you, freight collect. DSI shall have no responsibility for any deficiency resulting from accidents, misuse, modifications, power disturbances (including use of a power supply not specified by DSI), or various other forms of disaster, e.g., earthquakes, floods, etc.

PLEASE DO NOT ATTEMPT TO RETURN ANY ITEM PRIOR TO RECEIVING A RETURN MATERIAL AUTHORIZATION (RMA) NUMBER FROM DATACOM CUSTOMER SERVICE AT (315) 463-9541

Limitation On Liability

The warranties set forth above are exclusive and in lieu of all other warranties. Datacom Systems, Inc. (DSI) makes no other warranties, expressed or implied, and DSI expressly disclaims all other warranties, including but not limited to implied warranties of merchantability and fitness for a particular purpose. Moreover, the provisions set forth above state DSI's entire responsibility and your sole and exclusive remedy with respect to any breach of warranty or contract.

No liability for consequential damages. Under no circumstances and under no theory of Liability shall DSI be liable for costs of procurement of substitute products or services, lost profits, lost savings, loss of information or data, or any other special, indirect, consequential or incidental damages, arising in any way out of the sale of, use of, or inability to use, any DSI product or service, even if DSI has been advised of the possibility of such damages.

1 What's in the Package



T1/E1-PT Tap

2 Introduction

The T1/E1-PT is a directional single-port full-duplex device that provides an easy method to rapidly and effectively deploy your analysis tools to monitor T1/E1 traffic between your network devices. Typically the tap is installed on a critical T1/E1 link in the network where monitoring and analysis capabilities are important.

T1/E1-PT features and benefits:

- T1/E1 compatible
- Non-intrusive monitoring device
- Standard RJ45 connectors

3 T1/E1-PT Specifications

Feature	Specification
Channel	One directional T1/E1
Cable Type	CAT 5E
Port Connectivity	
LINE	RJ45
NETWORK	RJ45
TAP	RJ45
Distance Limit	90 meter maximum length between network end-points. Tap typically 1 meter.
Power Requirements	none
Operating Temperature	0° to 40° C (32° to 104° F)
Storage Temperature	-30° to 65° C (-22° to 149° F)
Humidity	Less than 95° C non-condensing
Dimensions	1.10" (H) x 5.75" (W) x 5.75" (D) (includes rack mount bracket) 28 mm (H) x 146 mm (W) x 146 mm (D)
Weight	Unit - 12 ounces; Shipping - 2 pounds

4 Installing a T1/E1-PT in an Equipment Rack

Prior to putting the T1/E1-PT in a standard 19-inch rack you may want to contact your T1/E1-PT representative to discuss a rack mount option or ...



T1/E1-PT with thumbscrew bracket to mount in RMC-3 rack mount



Three devices shown mounted in rack mount option

5 Functional Operation

Refer to **FIGURE 1** for a diagram of the functional operation of the T1/E1-PT .

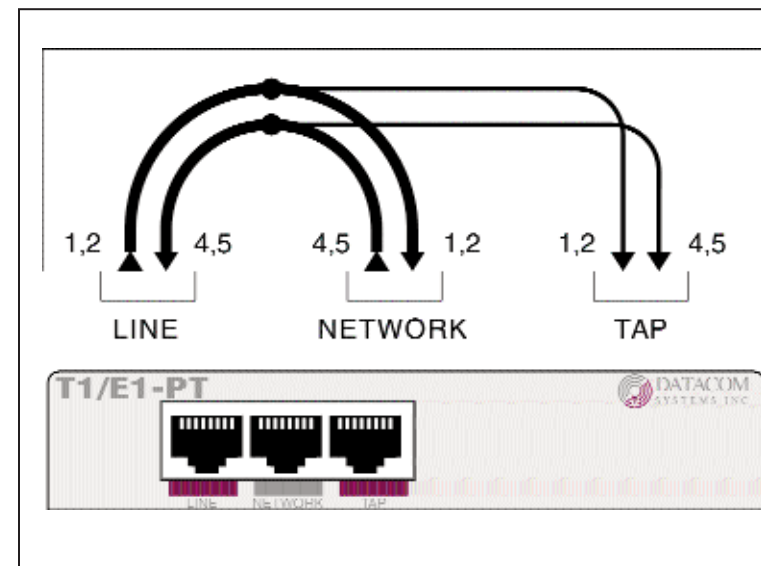

FIGURE 1 — T1/E1-PT Functional Diagram