

Compliance Testing

CAUTION: Changes or modifications to this unit not expressly approved by the party responsible for compliance could void the user's authority to operate the equipment.

CE Certifications

This equipment has been tested and found to meet the radiated and conducted emission limits for **EN 61000-6-3:2001**, **EN 61000-6-4:2001** and a **Class A** product of **EN 55022** to the **EMC Directive 89/336/EEC** requirements.

This equipment has been tested and found to meet levels of **EN 6100-4-2** Electrostatic Discharge, of **EN 61000-4-3** Radiated Susceptibility, of **EN 61000-4-4** Electrical Fast Transient/Burst, of **EN 61000-4-5** Surge, and **EN 61000-4-6** Conducted Susceptibility to the **EN 61000-6-1:2001** generic immunity standard requirements and meets the **Class A** requirements for **EN 61000-3-2** and **EN 61000-3-3**.

This equipment has completed the Product Safety Review and found to meet the **EN 60960** Safety of Information Technology Equipment standards to the **Low Voltage Directive 98/68/EEC** requirements.

Copyright

Copyright © 2006 by Datacom Systems, Inc. All rights reserved. Printed in the United States of America. No part of this publication may be reproduced, stored in a retrieval system, or transmitted, in any form or by any means, electronic, mechanical, photocopying, recording, or otherwise, without the prior written permission of Datacom Systems, Inc. To obtain this permission, write to the attention of the Datacom Systems legal department at 9 Adler Drive, East Syracuse, New York 13057-1290, or call 315-463-9541.

Customer Service

This Quick Installation Guide was written to help you get to know your new 10/100/1000-TAP quickly and easily. We would welcome any comments or suggestions you may have regarding this Quick Installation Guide. Please send your remarks and recommendations via mail, telephone, facsimile, or Internet E-mail.

Datacom Customer Service personnel are available from 8:30 AM to 5 PM Eastern time, weekdays. Customer Service is available via telephone, facsimile, and Internet E-mail. Outside of support hours, please leave a voice message and our Customer Service Staff will return your call as soon as possible.

Mail: Datacom Systems, Inc.
Customer Service
9 Adler Drive
East Syracuse, NY 13057-1290

Tel: (315) 463-9541

FAX: (315) 463-9557

E-mail: support@datacomsystems.com

World Wide Web

You can obtain additional information about Datacom Systems, Inc. and its products and services from the World Wide Web at <http://www.datacomsystems.com>.

DATAKOMsystems® 10/100/1000-TAP

Quick Installation Guide

1000 BaseT Functional

Refer to the 1000 BaseT Functional Diagram.

10/100 BaseT Functional

Refer to the 10/100 BaseT Functional Diagram.

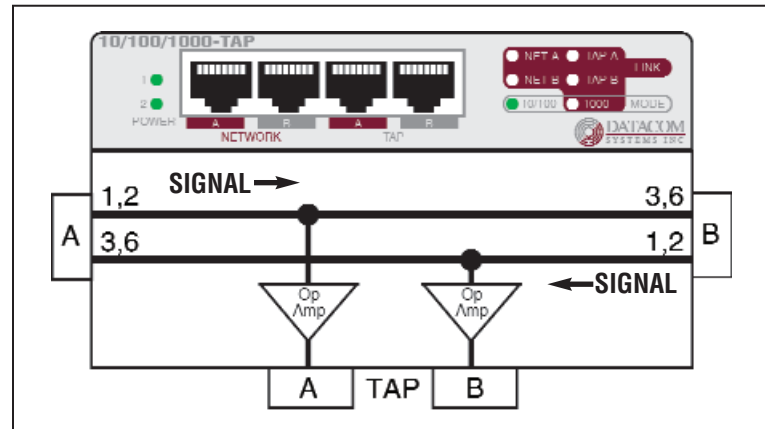

10/100 BaseT Functional Diagram

With the position of the 10/100 or 1G slide switch in the 10/100 position the 10/100/1000-TAP functions as a truly passive 10/100 tap. The passive tap uses a simple form of physical passive tapping. The 10/100/1000-TAP is a truly passive tap and adheres to the following: **if power to the tap is lost or restored there is never any change in the state of the tapped link.**

The 10/100 BaseT endpoint devices are attached via twisted pair cable. Only one signal is present on the transmit and/or receive pair, no multiplexing.

NOTE: •When in 10/100 (10/100 BaseT) mode of operation, the **LINK** lights are non-active because of the passive nature of the tap.

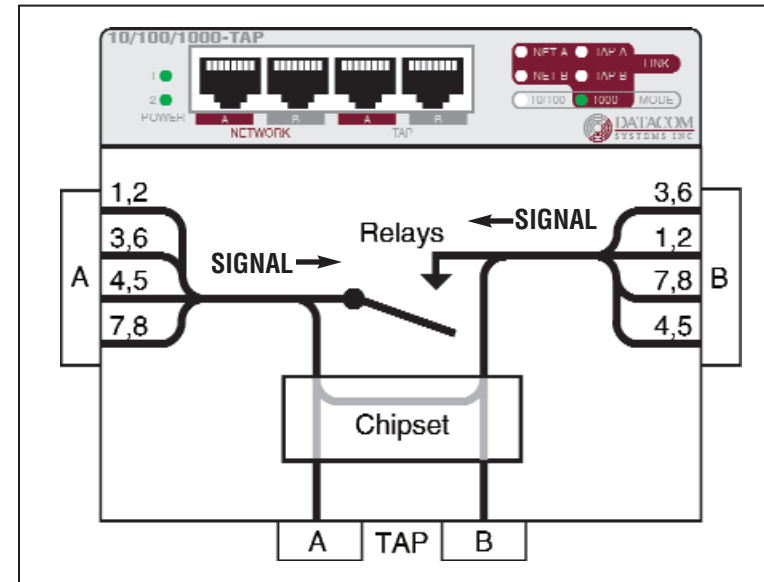

1000 BaseT Functional Diagram

With the position of the 10/100 or 1G slide switch in the 1G position the 10/100/1000-TAP functions as a power fault tolerant 1000 tap. The 1000 BaseT uses all four cable pairs for simultaneous transmission in both directions through the use of echo cancellation and a 5-level pulse amplitude modulation (PAM-5) technique. This power-fault-tolerant tap uses a powered tapping circuit to perform the functions necessary for endpoint device signal flow and copies to the tap ports.

Each endpoint device negotiates their tap network port connection and then signal flows through the tap circuit directly from one endpoint device to the other.

In the event of power loss to the tap, a set of relays fails to the closed position allowing signal to continue to flow through the tap.

NOTE: When in 1G (1000 BaseT) mode of operation, the **LINK** lights give a clear indication of link for each of the four ports.



February 2010

Part Number: 541-0104-A.01

The warranties set forth above are exclusive and in lieu of all other warranties. Datacom Systems, Inc. (DSI) makes no other warranties, expressed or implied, and DSI expressly disclaims all other warranties, including but not limited to implied warranties of merchantability and fitness for a particular purpose. Moreover, the provisions set forth above state DSI's entire responsibility and your sole and exclusive remedy with respect to any breach of warranty or contract.

No liability for consequential damages. Under no circumstances and under no theory of Liability shall DSI be liable for costs of procurement of substitute products or services, lost profits, lost savings, loss of information or data, or any other special, indirect, consequential or incidental damages, arising in any way out of the sale of, use of, or inability to use, any DSI product or service, even if DSI has been advised of the possibility of such damages.

Limitation On Liability

PLEASE DO NOT ATTEMPT TO RETURN ANY ITEM PRIOR TO RECEIVING A RETURN MATERIAL AUTHORIZATION (RMA) NUMBER FROM DATAKOM CUSTOMER SERVICE AT (315) 463-9541

Datacom Systems, Inc. (DSI) warrants that the hardware which it supplies will be free from significant defects in materials and workmanship for a period of two years from the date of delivery (Warranty Period), under normal use and conditions. In the event of any such defect, you can return an item of defective hardware, freight prepaid, to DSI during the Warranty Period, and DSI will repair or replace the defective equipment and return it to you, freight prepaid. If DSI determines that the equipment is not defective, it will return it to you, freight collect. DSI shall have no responsibility for any deficiency resulting from accidents, misuse, modifications, power disturbances (including use of a power supply not specified by DSI), or various other forms of disaster, e.g., earthquakes, floods, etc.

Warranty

1 What's in the Package



3 10/100/1000-TAP Specifications

Feature	Specification
Channel	10/100 BaseT or 1000 BaseT Ethernet
Cable Type	CAT 5E
Port Connectivity	NETWORK A NETWORK B TAP A TAP B
	RJ45 RJ45 RJ45 RJ45
Distance Limit	90 meter maximum length between network end-points. Tap typically 1 meter.
Power Requirements	External power supply 5 VDC, 2 A
Operating Temperature	0° to 40° C (32° to 104° F)
Storage Temperature	-30° to 65° C (-22° to 149° F)
Humidity	Less than 95° C non-condensing
Dimensions	1.10" (H) x 5.75" (W) x 5.75" (D) (includes rack mount bracket) 28 mm (H) x 146 mm (W) x 146 mm (D)
Weight	Unit - 12 ounces; Shipping - 2 pounds

2 Introduction

Refer to the general functional diagram of the 10/100/1000-TAP. The 10/100/1000-TAP is a non-directional single-port full-duplex device that provides an easy method to rapidly and effectively deploy your analysis tools to monitor 10/100 BaseT or 1000 BaseT traffic between your network devices. Typically the tap is installed on a critical 10/100 BaseT or 1000 BaseT link in the network where monitoring and analysis capabilities are important.

10/100/1000-TAP features and benefits:

- 10/100 BaseT and 1000 BaseT compatible
- Non-directional inline tap
- Full duplex monitoring
- Non-intrusive monitoring device
- Power fault tolerant
- Standard RJ45 connectors

4 10/100 BaseT or 1000 BaseT?

IMPORTANT: Before putting the 10/100/1000-TAP into a network, *the operating speed of the tap must be selected to match the speed of the network link.* A slide switch is accessible through the rear panel to select either 10/100 or 1G to match the speed of the network link.

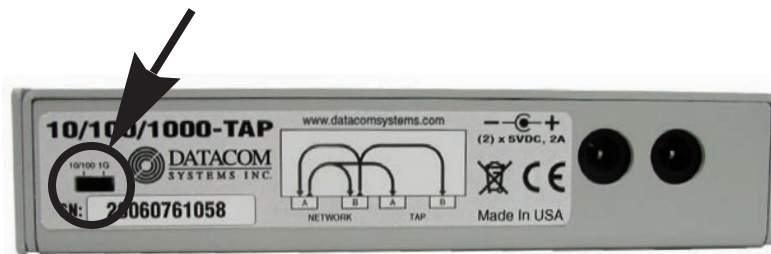

IMPORTANT: When set at 1G to match a 1000 BaseT network, *make certain that the endpoint devices have established link before powering the tap.* This ensures that the endpoint devices are able to renegotiate link during a tap power failure.

The 10/100/1000-TAP is an extremely versatile tap that provides the capability to monitor either 10/100 BaseT or 1000 BaseT traffic between your network devices. Depending on the position of the 10/100 or 1G slide switch, the 10/100/1000-TAP functions as a truly passive 10/100 tap or as a power-fault-tolerant 1000 tap, respectively.

5 Installing a 10/100/1000-TAP in an Equipment Rack

Prior to putting the 10/100/1000-TAP in a standard 19-inch rack you may want to contact your Datacom Systems Inc representative to discuss an optional rack mount.



10/100/1000-TAP with thumbscrew bracket to install in RMC-3 rack mount



Three different products shown installed in optional RMC-3 rack mount

6 Connecting a 10/100/1000-TAP to the the Network

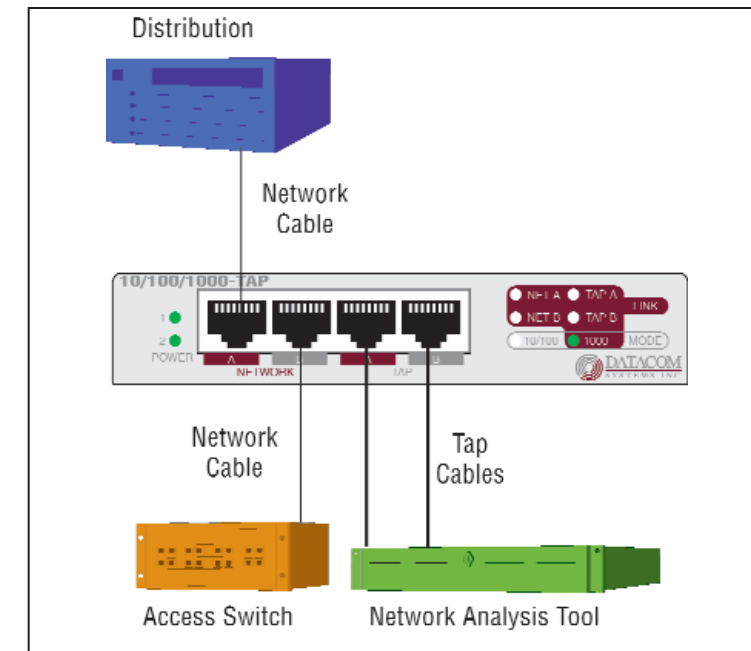

10/100/1000-TAP Connectivity Diagram

To connect the 10/100/1000-TAP into the network, refer to the Connectivity Diagram and follow these steps:

IMPORTANT: *The maximum length of 90 meters must not be exceeded between end-points.*

1. Connect one of the network device cables to the 10/100/1000-TAP RJ45 port **NETWORK A** connector.
2. Connect the other network device cable to the 10/100/1000-TAP RJ45 port **NETWORK B** connector.

IMPORTANT: When set at 1G to match a 1000 BaseT network, *make certain that the endpoint devices have established link before powering the tap.* If link is not indicated at the endpoint devices, reverse the tap **NETWORK A** and **NETWORK B** connection to establish link. This ensures that the endpoint devices are able to renegotiate link during a tap power failure.

3. Connect one tap cable from the 10/100/1000-TAP RJ45 port **TAP A** connector into one port of the Network Analysis Tool interface card.
4. Connect the other tap cable from the 10/100/1000-TAP RJ45 port **TAP B** connector into the other port of the Network Analysis Tool interface card.
5. Connect both Power Supply barrel connectors into both the **POWER** ports of the 10/100/1000-TAP and then plug the Power Supplies into separate external power source wall receptacles for reliable redundant power. The **POWER** LEDs to the left of the RJ connectors illuminates indicating power is on.

In any case, a couple of equipment considerations should be noted:

- Do you have universal or wide spacing flanges?
- The 10/100/1000-TAP occupies 1 unit of space when properly fastened in a universal flange. The 10/100/1000-TAP occupies part of 2 adjoining units of space when improperly fastened in a wide spacing hole of a universal or wide-space flange.

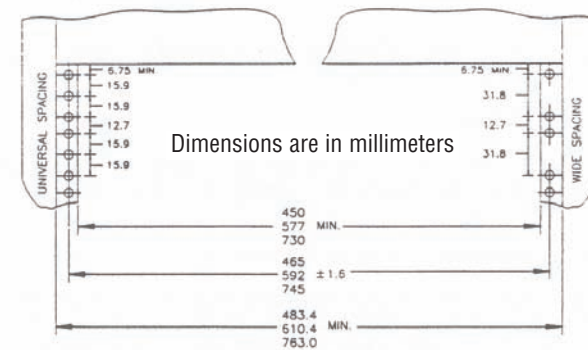

ANSI/EIA-310-D-1992 Mounting Flange Dimensional Requirements

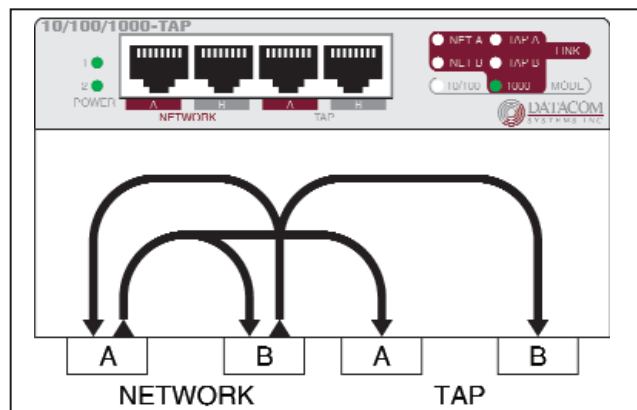

10/100/1000-TAP General Functional Diagram